

Custom manufacturing of single footing and globlets

07 Čerčany

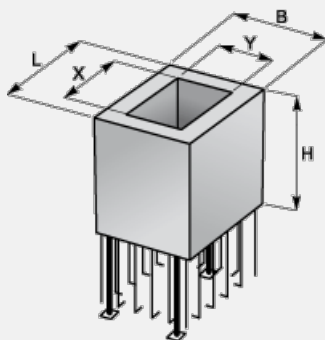

Trademark	Dimensions (cm)		
	L	B	H
ZV 002	Čerčany max 220 Litice max 135	Čerčany max 140 Litice max 135	Čerčany max 150 Litice max 135

Usage:

Prefab single footings speed up the foundation works at the construction of prefab skeletal systems and significantly reduce the labour content.

The element dimensions are designed for commonly used pole dimensions and the dimensions of skeleton structures space layout. Dimensions, reinforcement and concrete grade, etc. is specified in the implementation documentation of the work. It is made with smooth bearing area or with protruding concrete reinforcement for creating a subsequent monolith with footing bottom part when a prefab footing with protruding reinforcement sits in the bottom part of shuttering or in accurately excavated hole on the base concrete and both footing parts make for one monolith.