

Made-to-order manufacture of bridge cornices

41 Litice

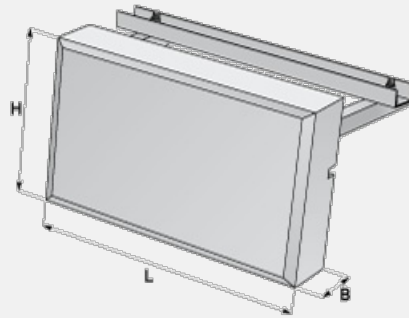

Trademark	Dimensions (cm)			Concrete Class
	L	B	H	
IZM 499/19	*	*	*	C 30/37-XF4

Usage:

* – as per the project documentation, without any limitations

Face plate components of rectangular shape in width 120 mm produced in basic heights 450mm, 600mm and 750 mm. The height can be adjusted as per the specific project documentation. The prefab length of 1990 mm can be shortened or lengthened up to the length of 3000mm as necessary. Face side is made of fair-face concrete with smooth surface or the design as per the project requirements. Underside is equipped with a longitudinal groove 25/25 mm for inserting permanent shuttering. Under the groove the surface is smoothed, above the groove it is roughened. Prefab component is used as a moulding piece to make bridge mouldings, retaining walls, etc.

Moulding pieces are delivered together with steel anchor material. Anchorage method can be modified as per the received project documentation.