

Inlet socket reinforced-concrete pipe DN

1000

07 Čerčany

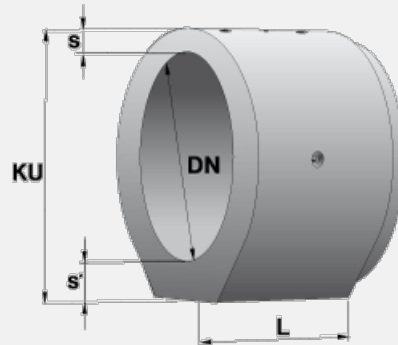

Trademark	Dimensions (cm)					Concrete Class	Volume (m3)	Weight (kg)
	L	D	D_1	T_1	T_2			
TZP 022-19	100	100	138	19	19	C 50/60-XF4	0,6940	1700

Usage:

The reinforced concrete duckfoot tubes are intended for construction of single- and multi-hole culverts under trackbed and roadbed. They are designed according to standard ČSN 73 6203 for railway load given by the load train ČSD T, and road load given by class A. They are dimensioned for extra-banking height 0.55 up to 9 m (crack width 0.1 mm) and 0.55 up to 12 m (crack width 0.2 mm). They are reinforced by concrete reinforcement BSt 550, namely in two layers with double-sided reinforcement cover 40 mm thick. The reinforced concrete duckfoot tubes are provided with built-in rubber sealing for joining with groove and tongue. On the ground of earthing against dispersion current they are provided with earth terminal. The top load V_u amounts for DN 800 - 296.8 KN, DN 1000 - 373.4 KN, DN 1200 - 408.0 KN.

The inlet reinforced concrete duckfoot tubes differ from normal reinforced concrete duckfoot tubes only in that they have no socket and they are inserted on the inlet side into the culvert.