

Drainage trough with griding with outlet

41 Litice

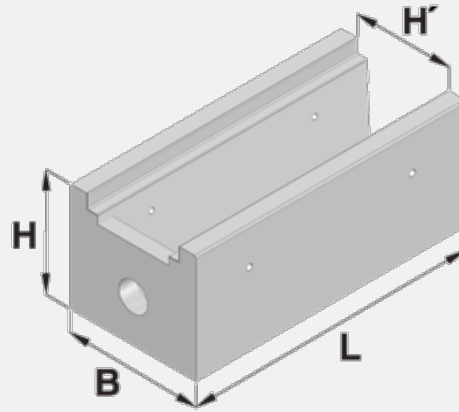

Trademark	Dimensions (cm)				Concrete Class	Volume (m3)	Weight (kg)
	L	B	H	H_1			
TZM 302-19	150,8	70	60	50,5	C 35/45-XF4	0,3683	902

Usage:

Drainage gutters with grating are reinforced concrete prefabs in the shape of the letter U covered by 3 pieces of plastic or cast-iron gratings with load capacity D400 according to ČSN EN 124. The contact surfaces of the gratings are reinforced with rolled steel L-shaped profiles. The prefabs are intended for creating drainage gutters for roadways, especially in front railway crossings, for parking and warehouse areas, transshipment points and ports. The parts are dimensioned for group 4 (class D400) according to ČSN EN 1433. At railway crossings, it is recommended to install drainage channels in order to ensure the stability of the subsoil at a distance of min. 2.5 m from the track axis. The drainage channel with a grid fully replaces the threshold outlet. No. 593 831 010 217. Forms an addition to the regular part of the drainage channel with a grid.